



**READ CAREFULLY
BEFORE INSTALLATION**



**WASH BEFORE
INSTALLING**

SUPER-BOLT FENDER FLARES SET TUNDRA

PART #: TO01A10

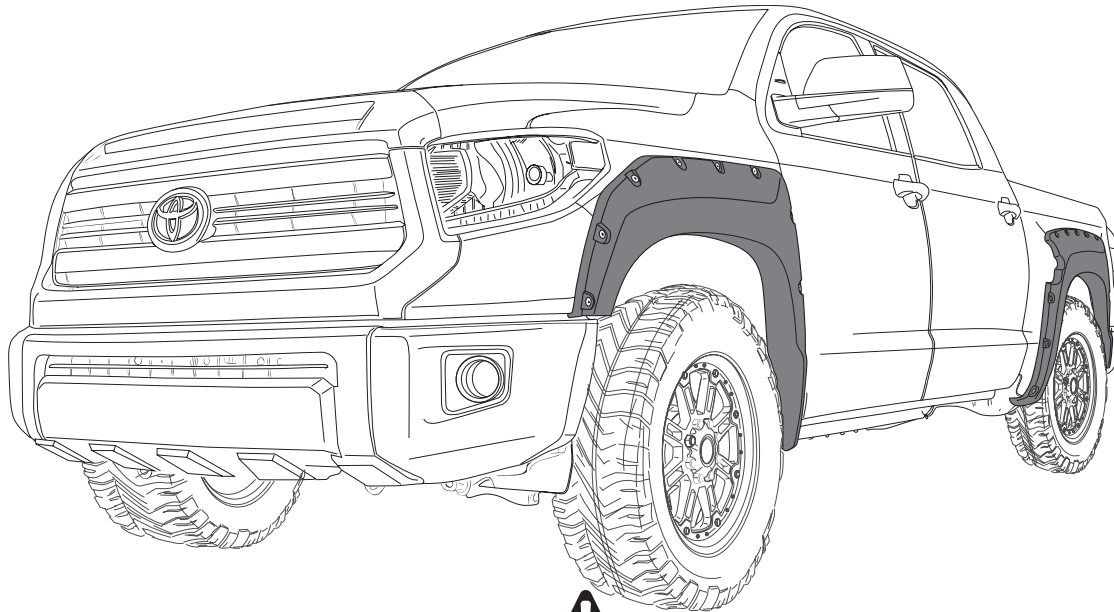

WARNING!! Do not install Hood Scoops or other Body Parts directly Over Wrapped areas. Before installation of the parts , you must leave at least a 1/4" (6mm) perimetral clearance "Free from Vinyl" surrounding the part, before Part installation.



WARNING!! Do not install Hood Scoops Over Vinyl or Over Plastic Stripes on the Hood: 3M Adhesive Tape and PUR Adhesive must always be in contact with the Sheet Metal of the vehicle.



WARNING!! Rust Prevention Oils and other Petrol Based Anti Rust Treatments for Vehicles may affect 3M's Double Adhesive Tape and Polyurethane Adhesive performance!



**WE RECOMMEND
2 PERSONS FOR
INSTALLATION**

AFTER INSTALLING

DOT NOT WASH CAR



24 hrs





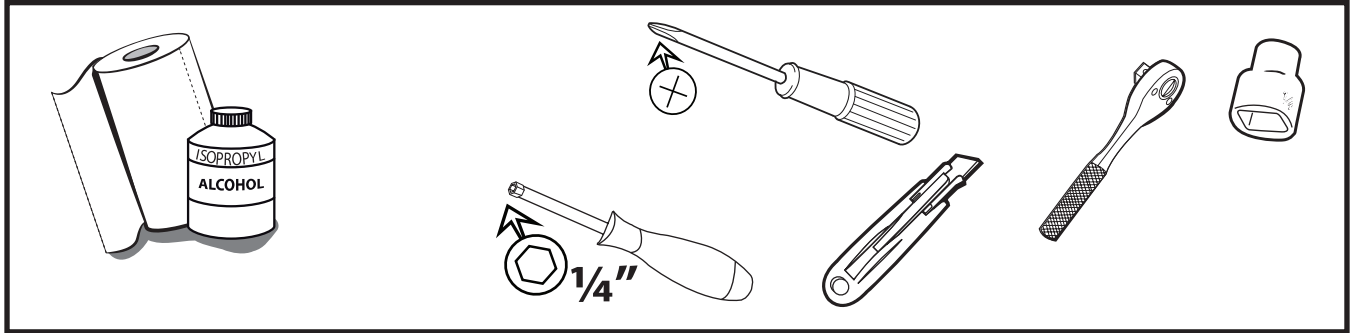









TOOLS

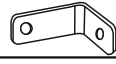
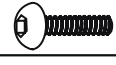

CHECK LIST

*Already installed in the part

ITEM	DESCRIPTION	DRAWING	AMOUNT
A	* SUPER-BOLTS' RUBBER STUDS		45 pcs
B	* STAINLESS SUPER-BOLT M6 X14		45 pcs
C	*STAINLESS LOCKNUT M6		19 pcs
D	PHILLIPS - HEX HEAD SEMS TAPPING SCREW M 6.3 X 25 M 16 M WASHER / 10 M		16 pcs
E	AUTOMOTIVE ADHESION PROMOTER TESA # 60153		1 pc
F	APPLICATION SPONGE		1 pc
G	GREASE PENCIL		1 pc
H	*PVC TRIM		33 ft
I	STAINLESS LOCKNUT M5		2 pcs
J	L-BRACKET		2 pcs
K	BUTTON HEAD STAINLESS SCREW M5 X 10		2 pcs
L	WASHER M5		2 pcs
M	THREADLOCKER 222		1 pc
N	SUPER-BOLT PRESSER		1 pc

The ideal temperature range of the part and the vehicle when installing must be 16°C (60°F) to 40°C (104°F), this guarantees a correct assembly.

1 REMOVE AND SAVE SCREWS

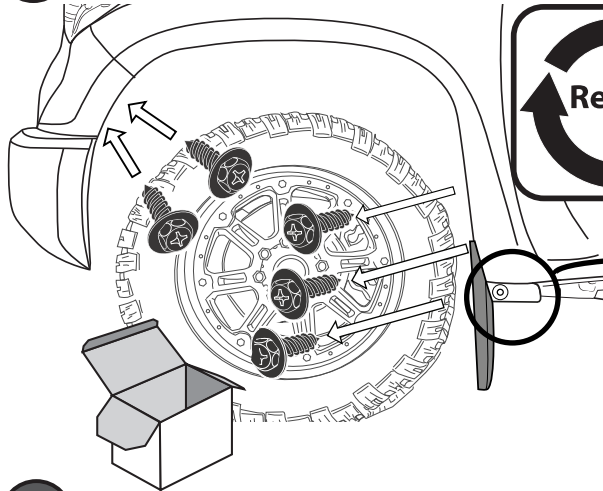

FRONT RIGHT & LEFT FLARE

! WASH WITH WATER, DETERGENT AND SOFT CLOTH OR SPONGE

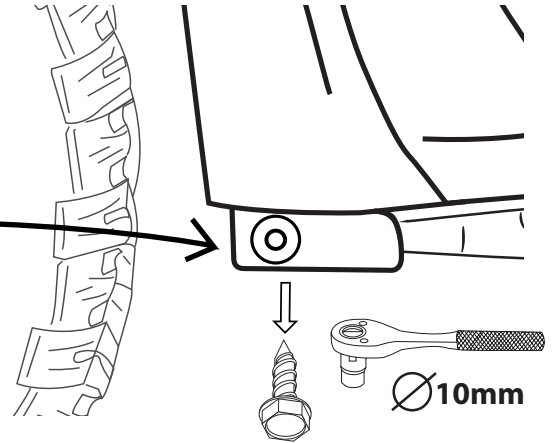

2 REMOVE MUD GUARDS

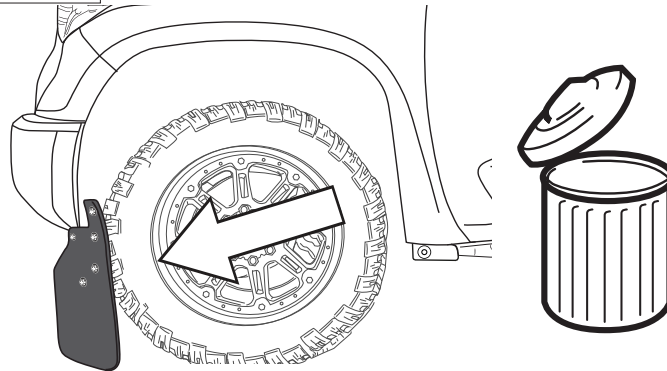

3 CLEAN

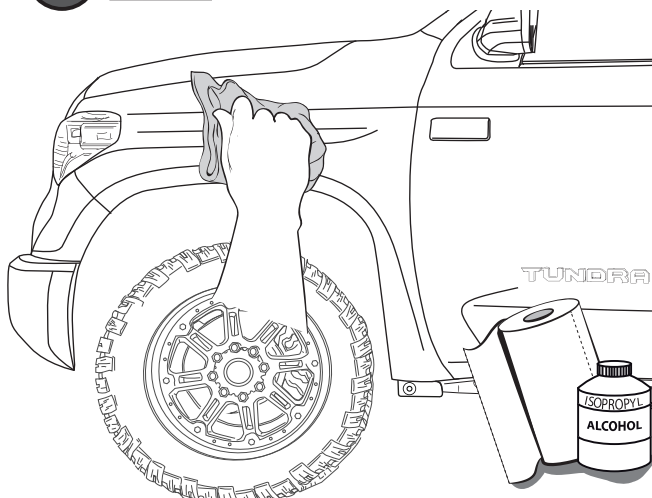

4 PRE-MOUNT

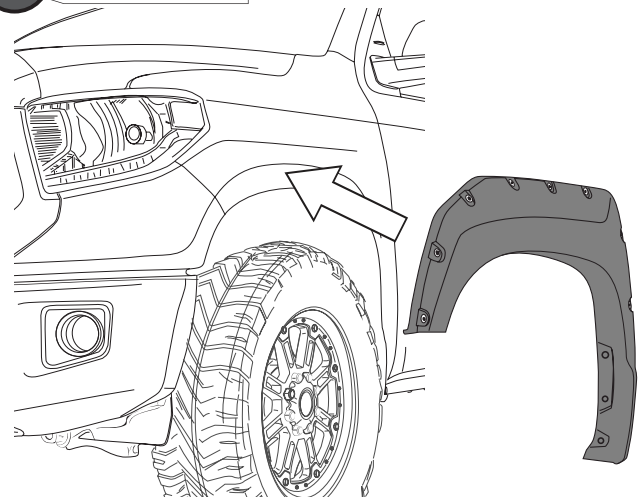

5 SECURE THE PART USING ORIGINAL SCREW

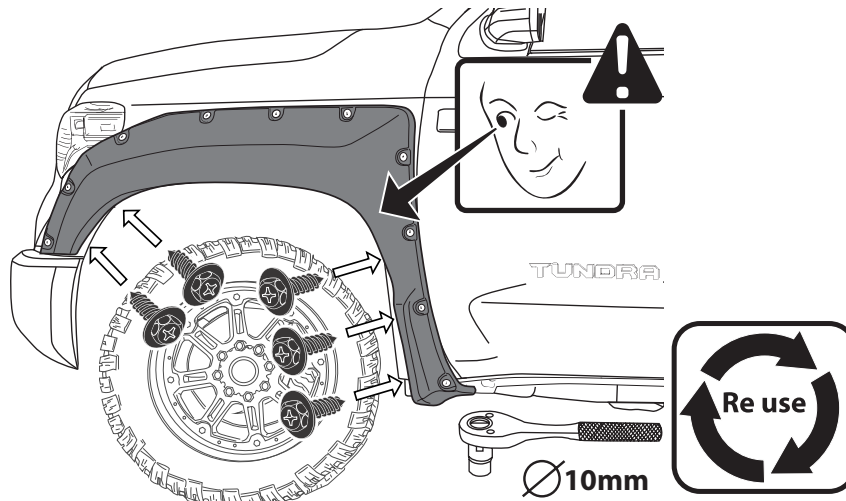

6 MARK SILHOUETTE AND SUPER-BOLTS POSITIONS

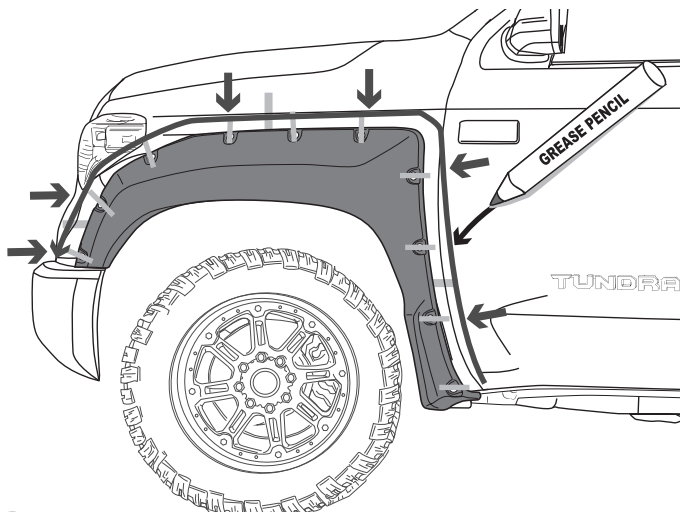

! HASH MARKS

DRAW CENTER HASH MARK WITH GREASE PENCIL AT CENTER, BOTH SIDES, ON EACH SUPER-BOLT AND SHEET METAL. THIS WILL ENSURE WHEEL FLARE WILL BE CENTERED TO GREASE PENCIL OUTLINE.

7 UNSCREW & REMOVE

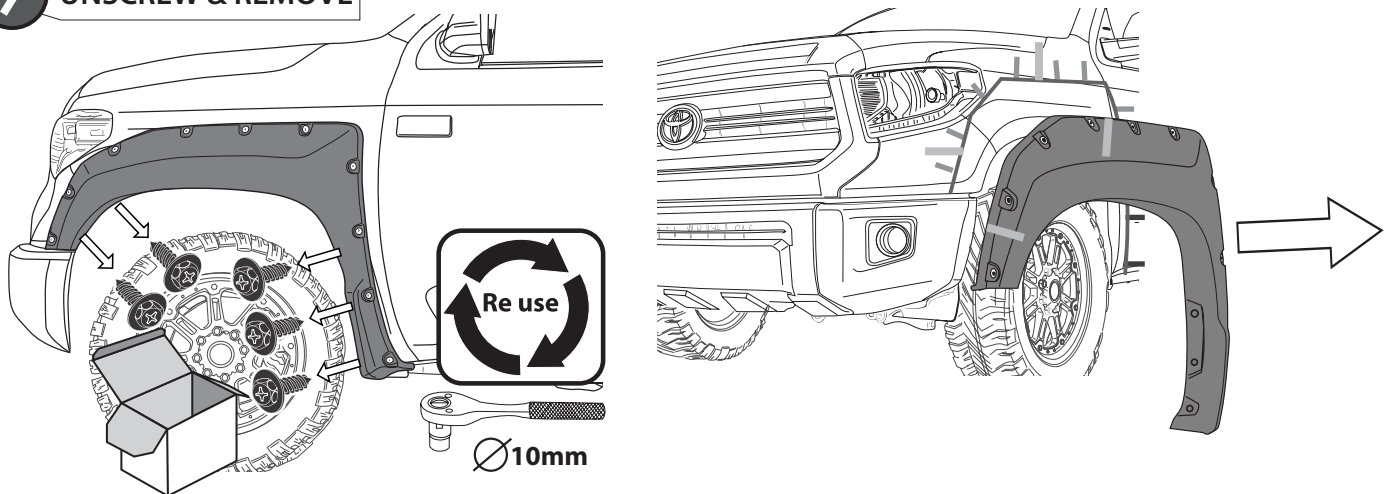

8 CLEAN  **FIRST CLEAN ALL OVER THE APPLICATION AREA WITH ALCOHOL**

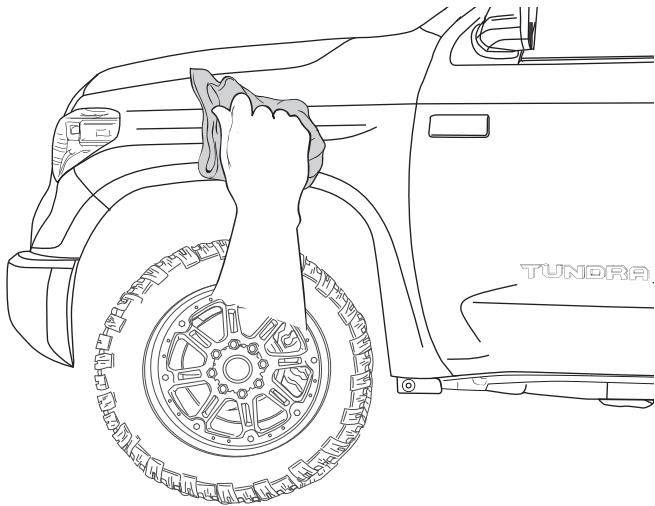

9 ADHESION PROMOTER

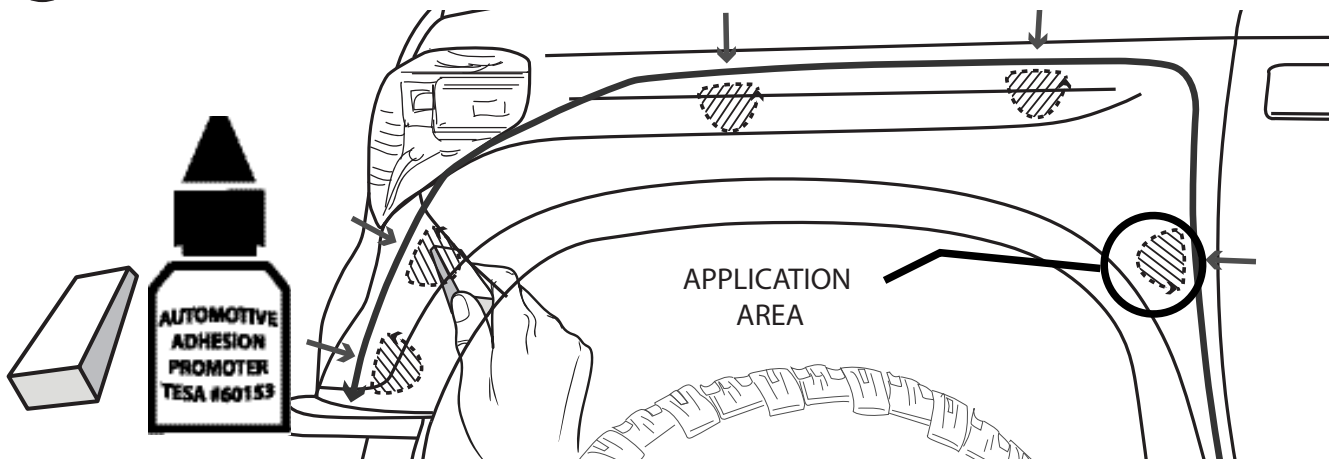

10 REMOVE LINER

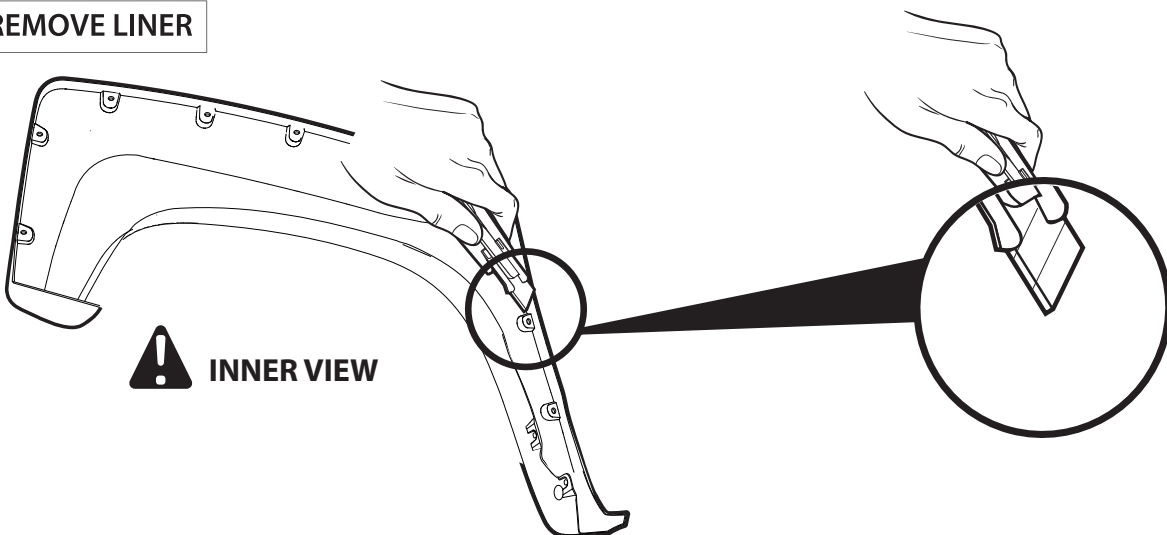

11 PRE-MOUNT  **ALIGN WHEEL FLARE TOP EDGE WITH THE GREASE PENCIL HASH MARKS AND PLACE.**

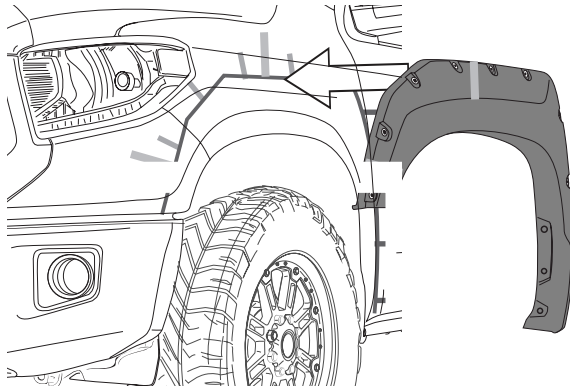

12 SECURE THE PART

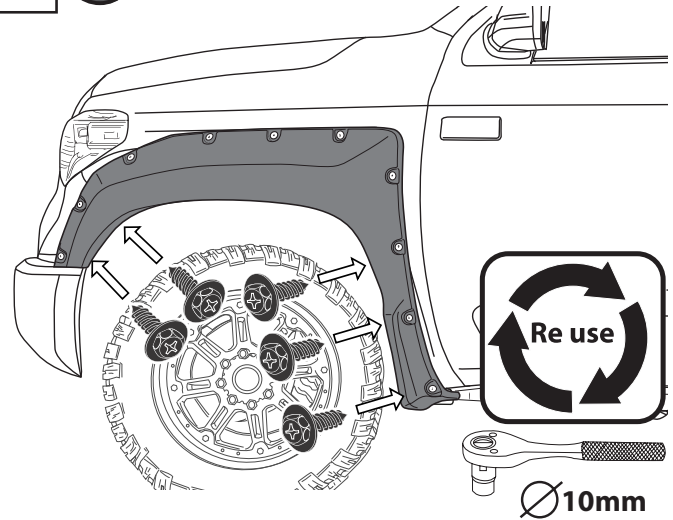

13 APPLY PRESSURE ON EACH SUPER-BOLT

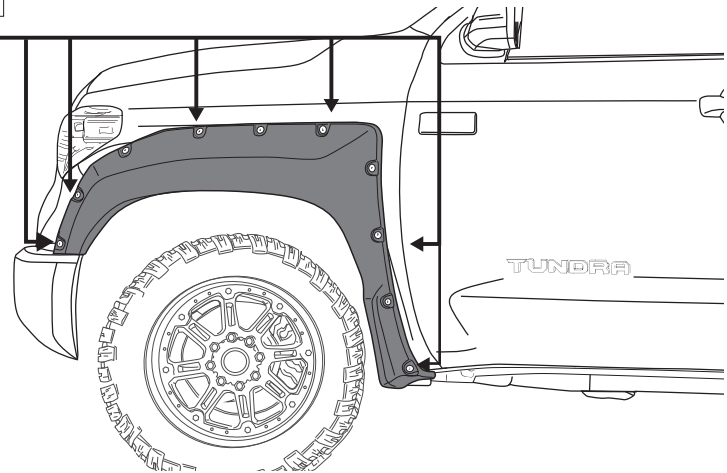
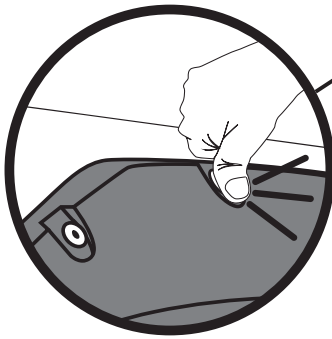

14 UNSCREW

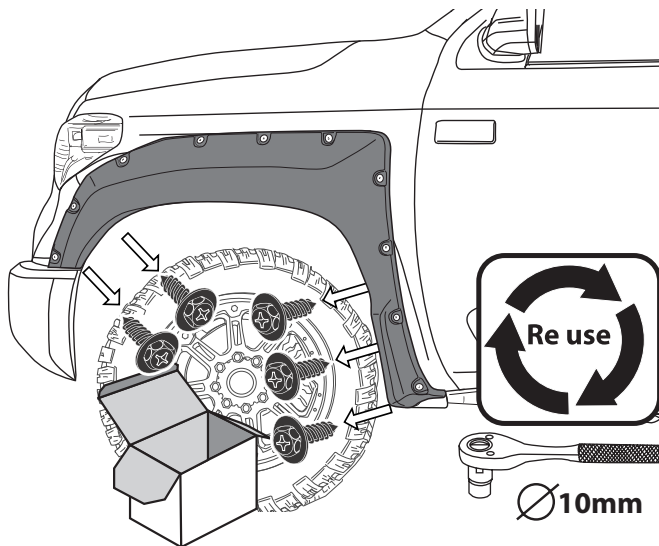

15 REMOVE SUPER-BOLTS (B)

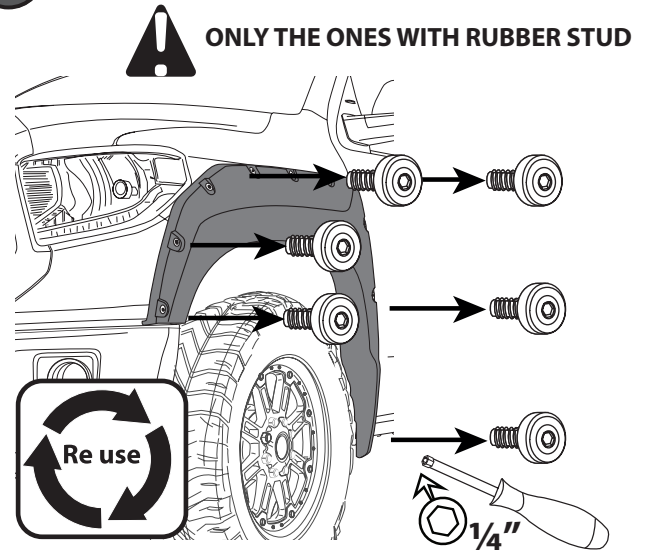

SUPER-BOLT INSTALLATION

16 PRESS SUPER-BOLTS STUDS

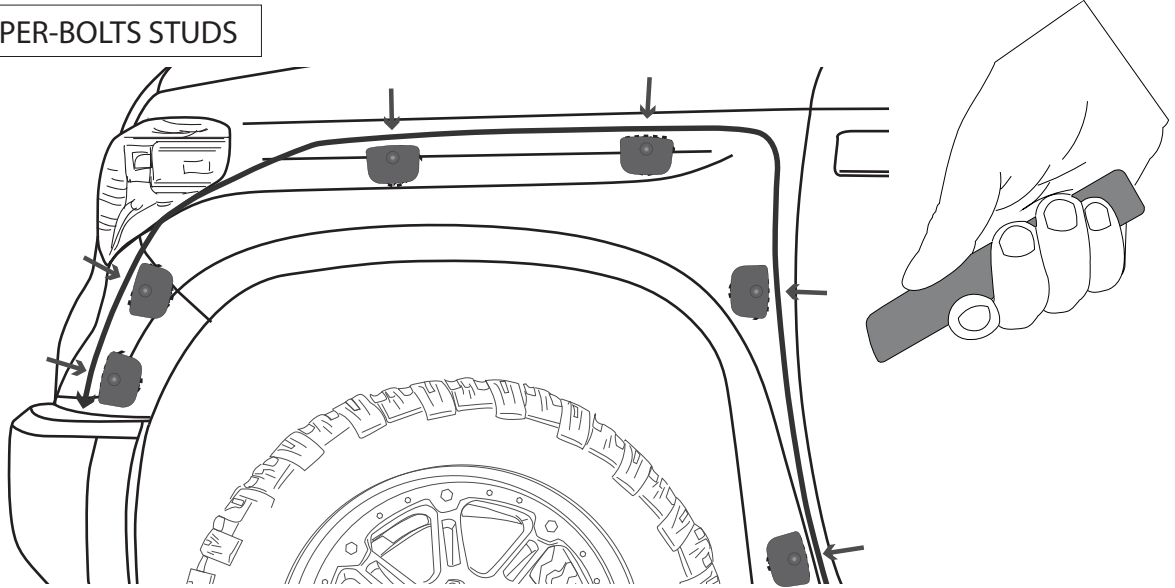

ATTENTION

FULL SURFACE CONTACT IS CRITICAL FOR GOOD ADHESION PERFORMANCE. ALWAYS APPLY FIRM PRESSURE WHEN MOUNTING ADD ON PARTS AND TAPES.



58 - 72 PSI

SUPER-BOLT STUDS

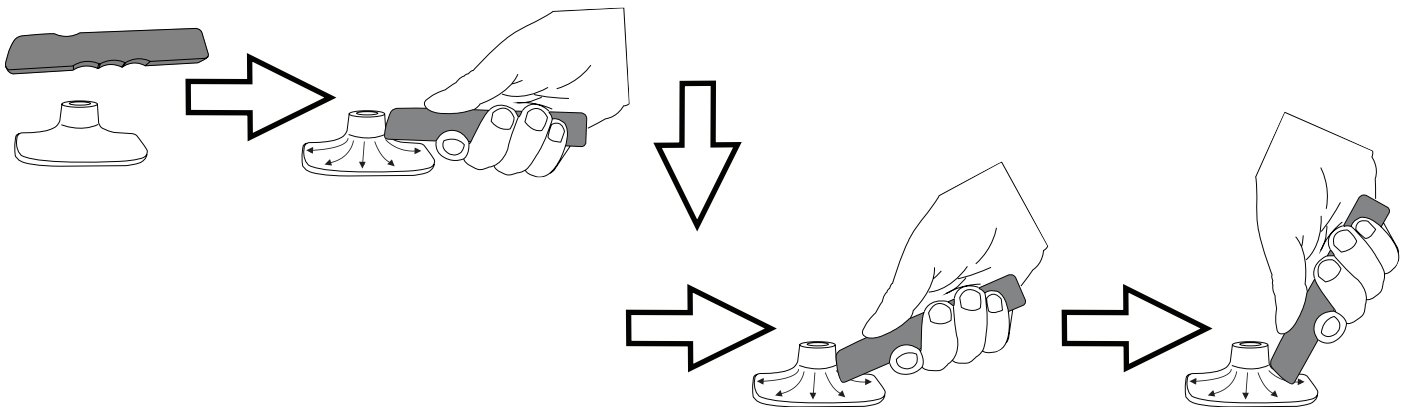

 **PRESSURE POINTS**

17 PLACE "L" BRACKET (I) WITH BUTTON HEAD SCREW M5 (J), WASHER M5 (K) & LOCKNUT M5 (L)

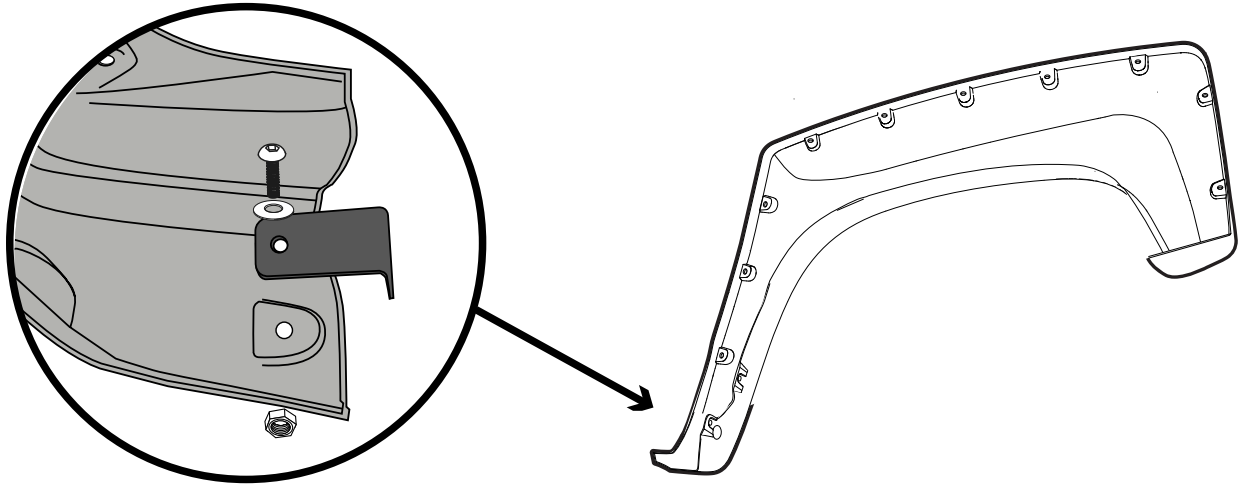

18 PLACE PVC TRIM

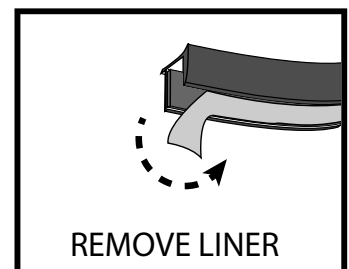
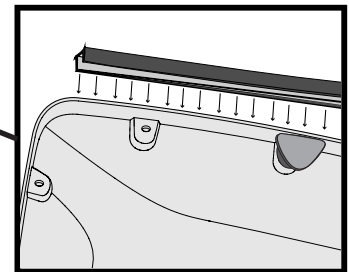
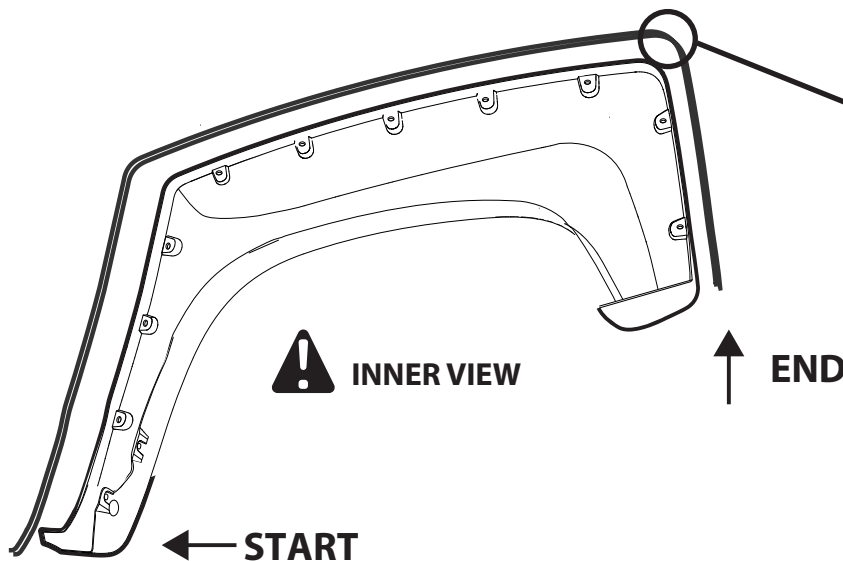
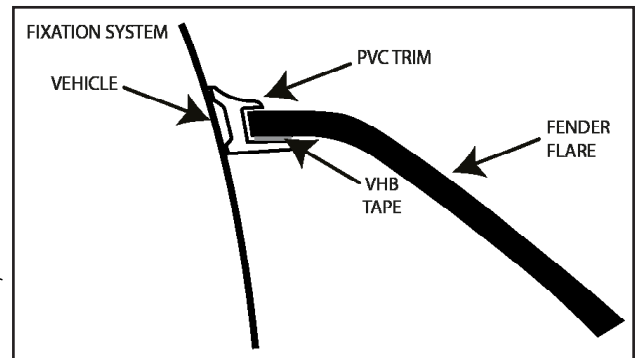
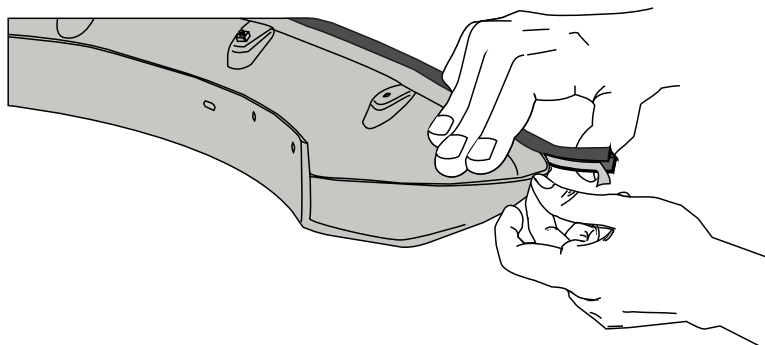

INSTALLATION MANUAL

19 PLACE

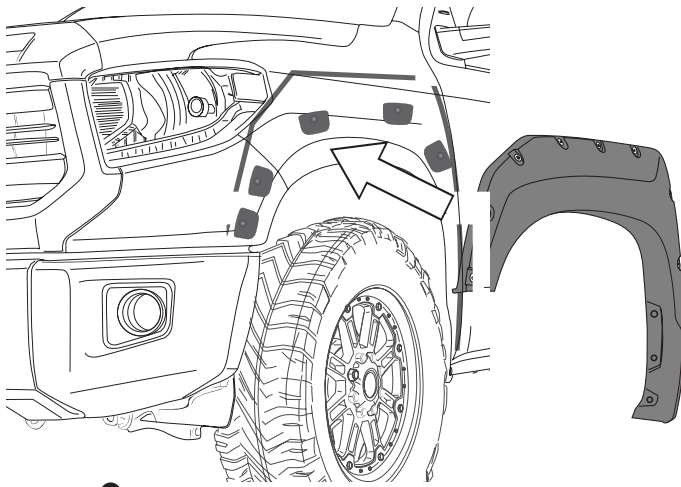

20 SECURE THE PART

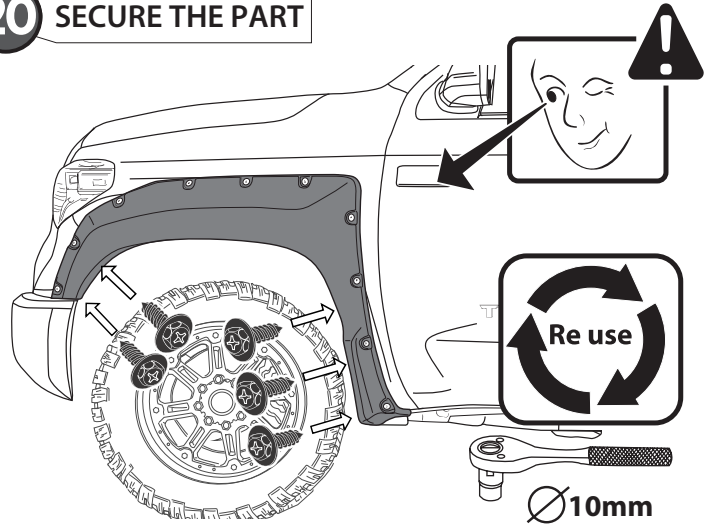

! ATTENTION

21 APPLY LOCTITE THREADLOCKER TO SUPER-BOLTS THREAD



22 PLACE SUPER-BOLTS

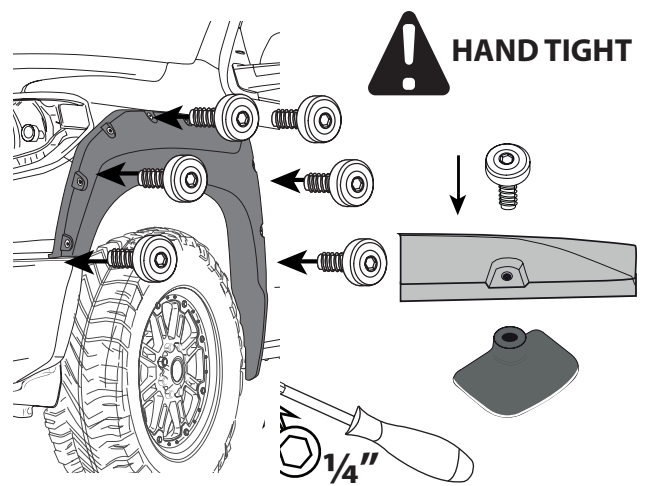

23 PIN UP BRACKET

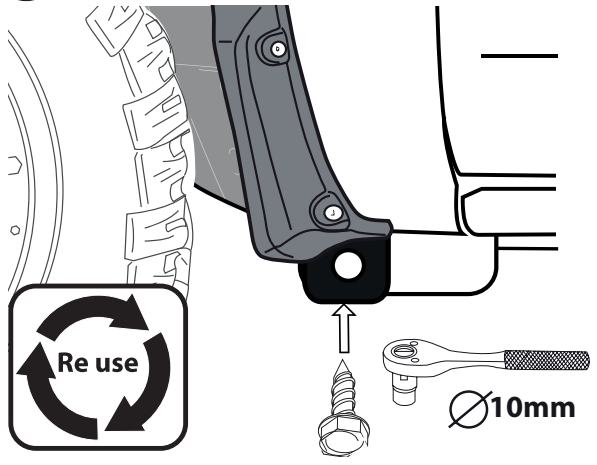

24 CLEAN THE GREASE PENCIL MARK

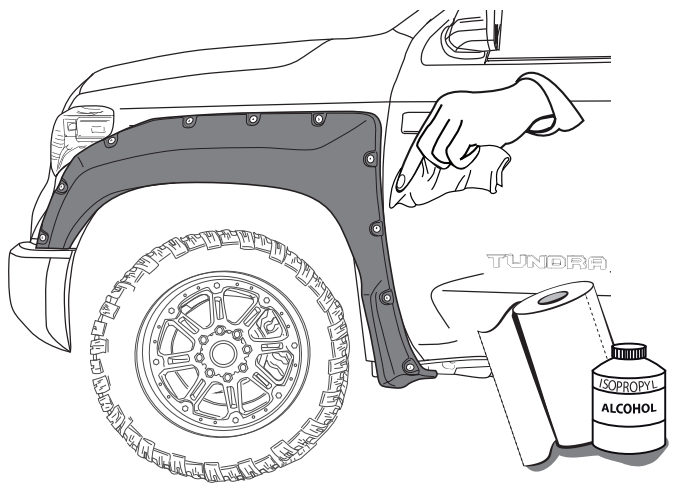

REAR RIGHT & LEFT FLARE

1 REMOVE AND SAVE SCREWS

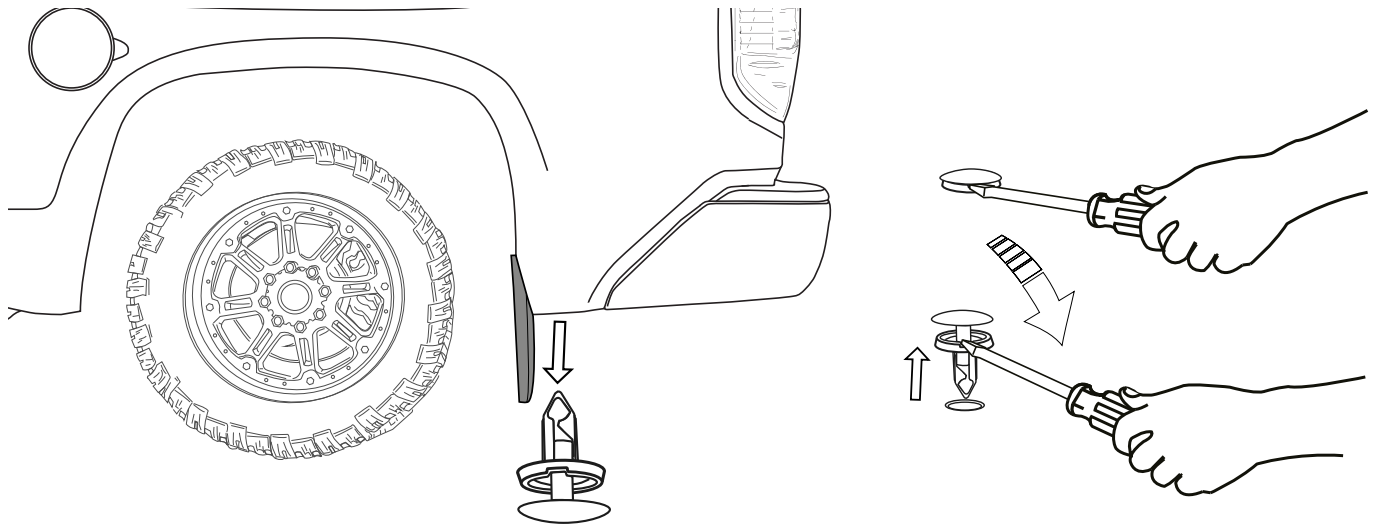
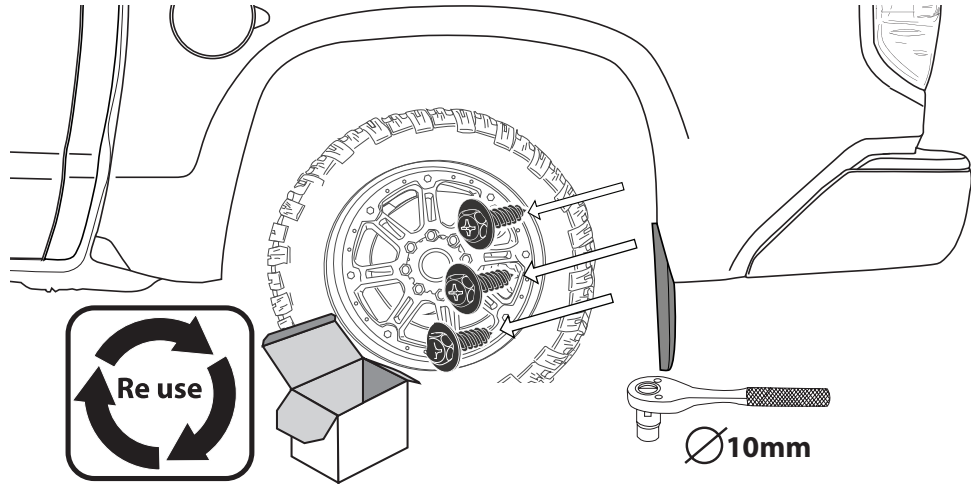

2 REMOVE MUD GUARDS

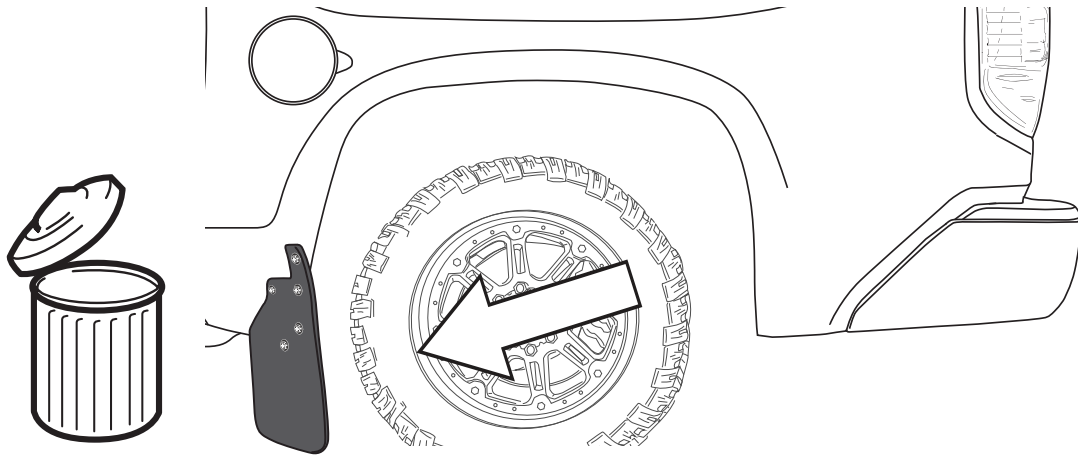

3 CLEAN

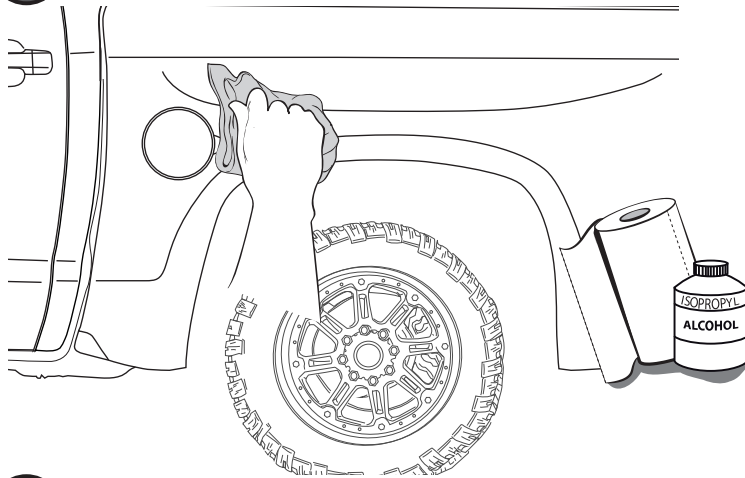

4 PRE-MOUNT

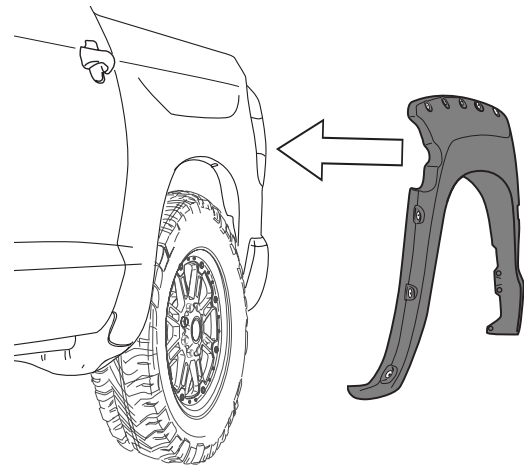

5 SECURE THE PART USING PHILLIPS SCREW 6.3X20 (D)

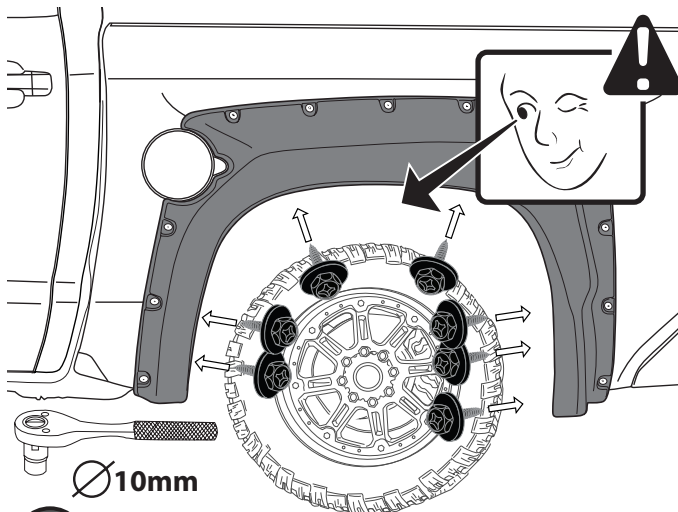

6 MARK

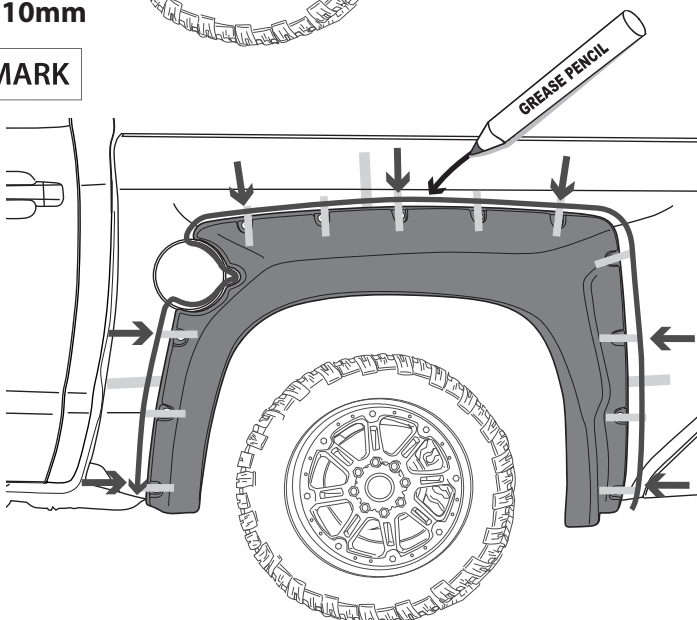

! HASH MARKS

DRAW CENTER HASH MARK WITH GREASE PENCIL AT CENTER, BOTH SIDES, ON EACH SUPER-BOLT AND SHEET METAL. THIS WILL ENSURE WHEEL FLARE WILL BE CENTERED TO GREASE PENCIL OUTLINE.

7 UNSCREW & REMOVE

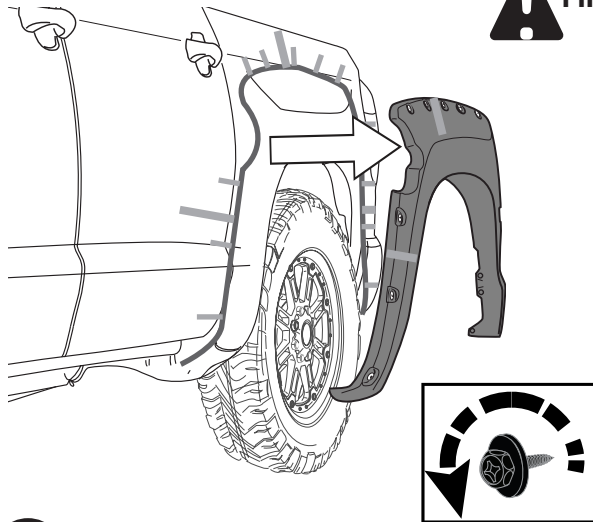

8 CLEAN



FIRST CLEAN ALL OVER THE APPLICATION AREA WITH ALCOHOL

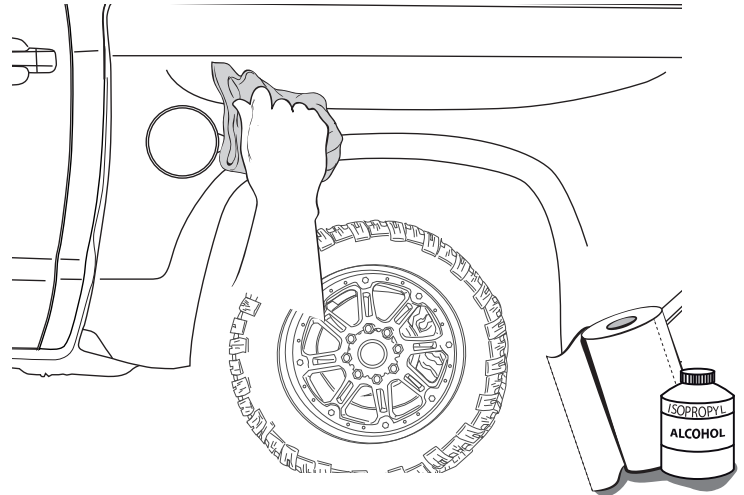

9 ADHESION PROMOTER

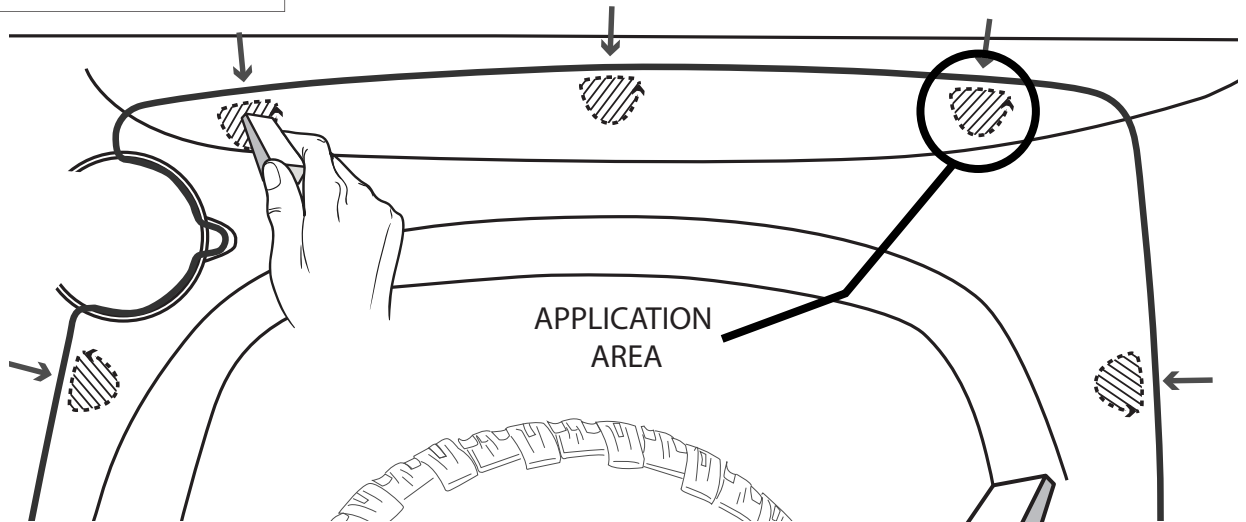

10 REMOVE LINER

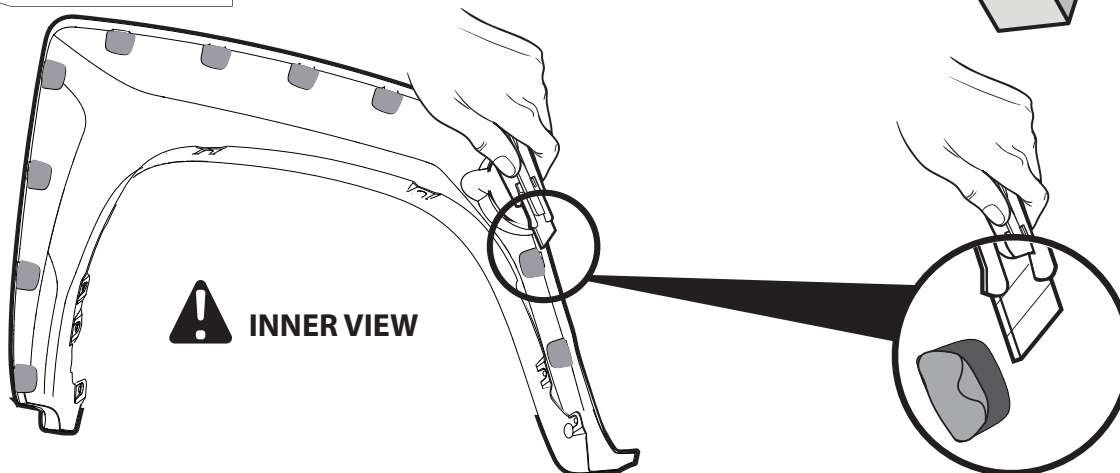

11 PRE-MOUNT

! ALIGN WHEEL FLARE TOP EDGE WITH THE GREASE PENCIL HASH MARKS AND PLACE.

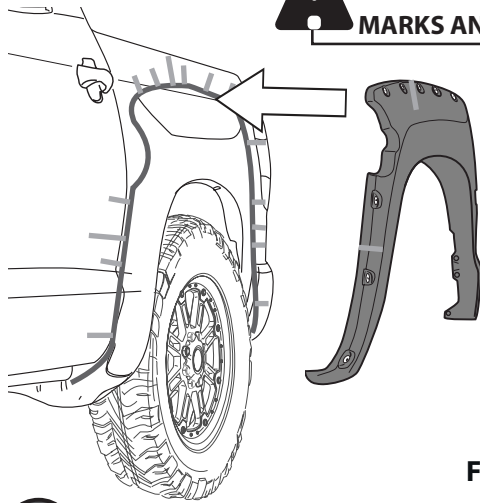

**WE RECOMMEND
2 PERSONS
FOR INSTALLATION**

12 SECURE THE PART

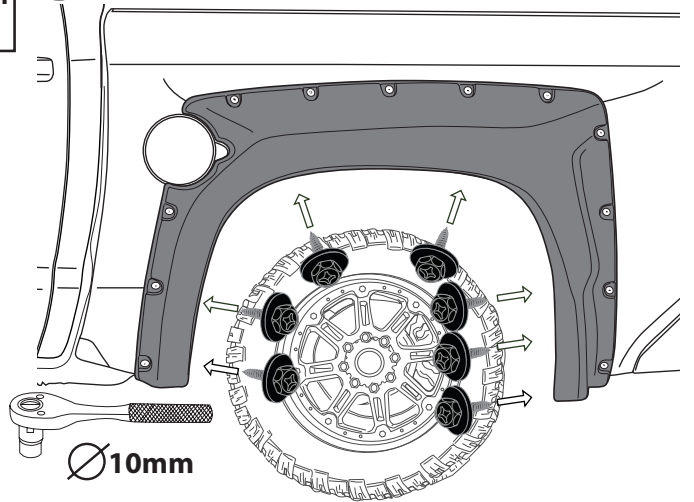

13 APPLY PRESSURE ON EACH SUPER-BOLT

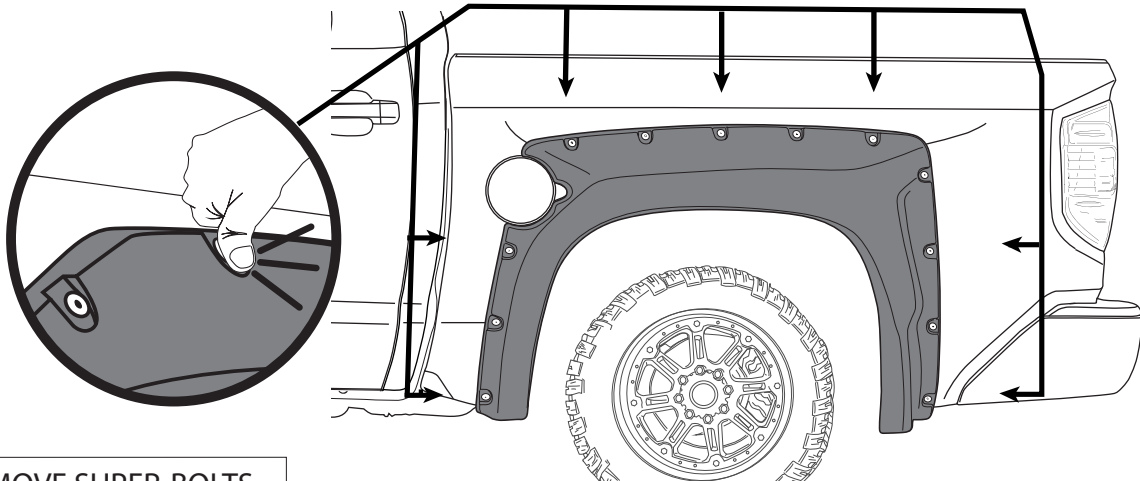

14 REMOVE SUPER-BOLTS

! ONLY THE ONES WITH RUBBER STUD

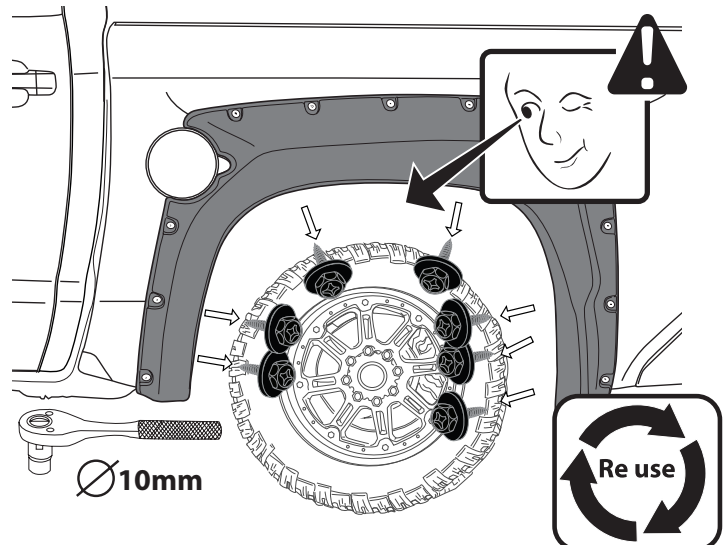
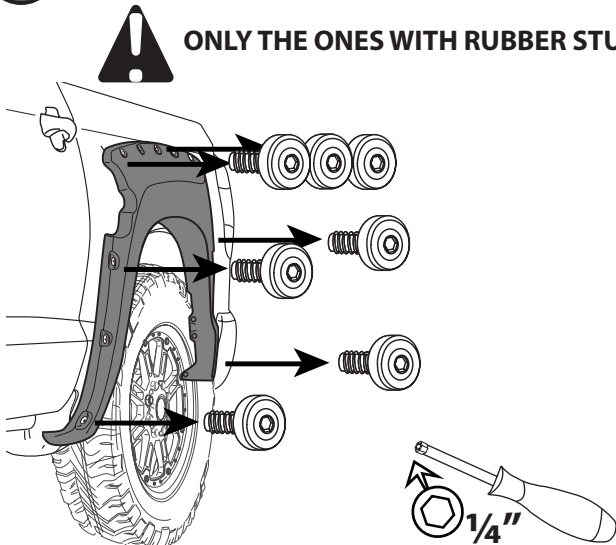

SUPER-BOLT INSTALLATION

15 PRESS SUPER-BOLTS STUDS (A)

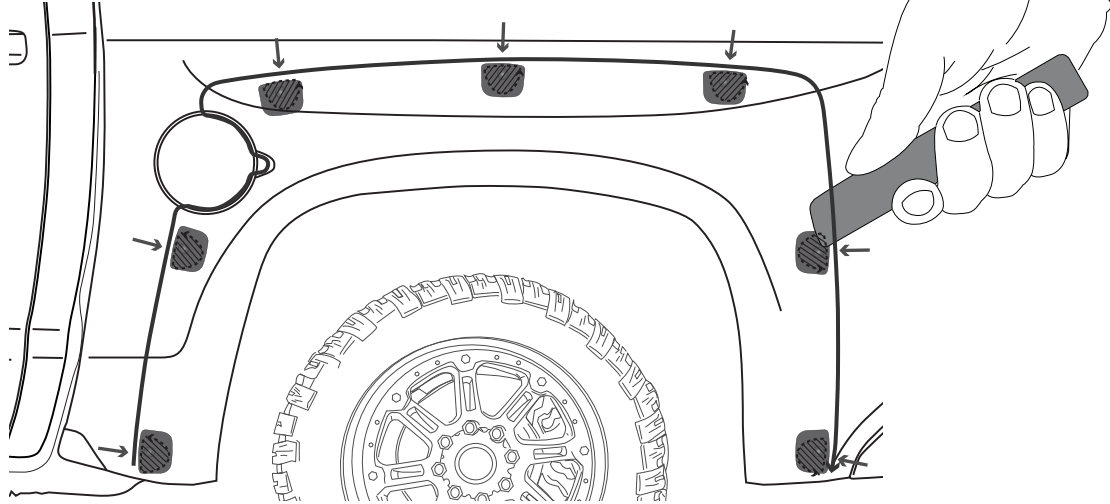

ATTENTION

FULL SURFACE CONTACT IS CRITICAL FOR GOOD ADHESION PERFORMANCE. ALWAYS APPLY FIRM PRESSURE WHEN MOUNTING ADD ON PARTS AND TAPES.



58 - 72 PSI

SUPER-BOLTS STUDS

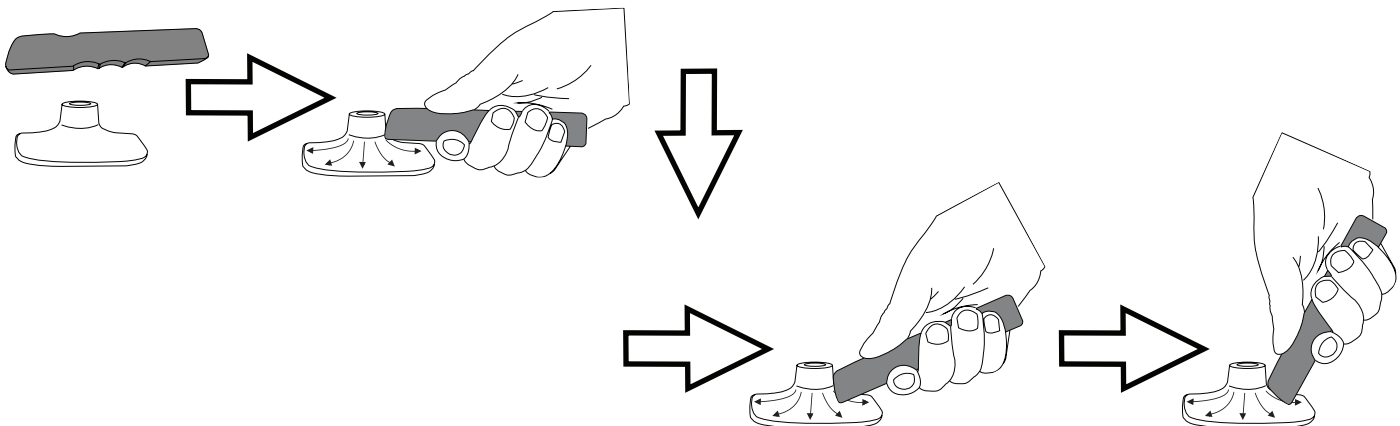

PRESSURE POINTS

16 PLACE PVC TRIM

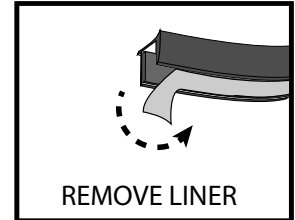
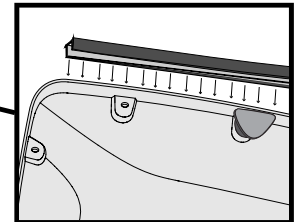
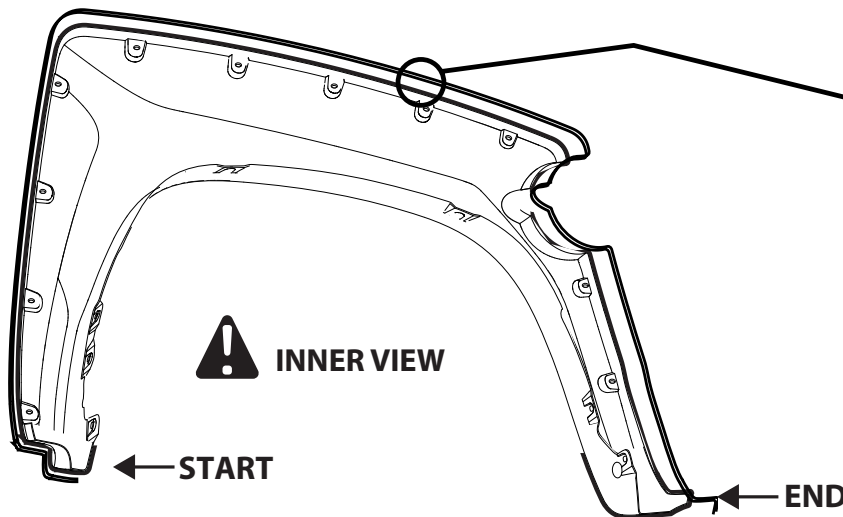
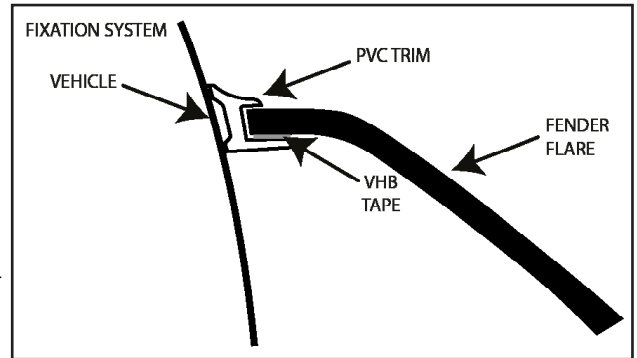
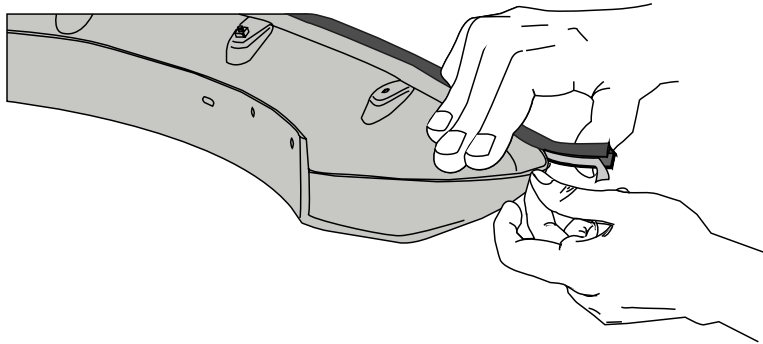

17 PLACE

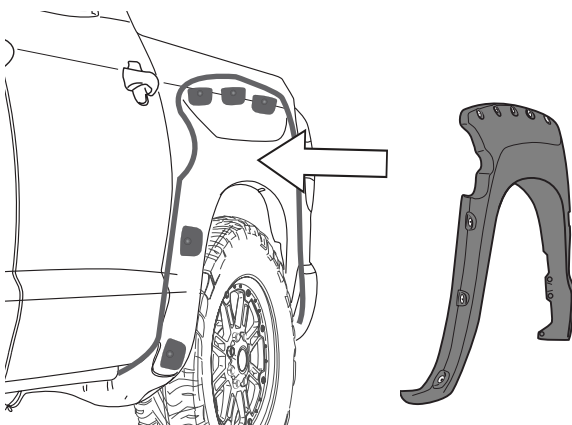

18 SECURE THE PART

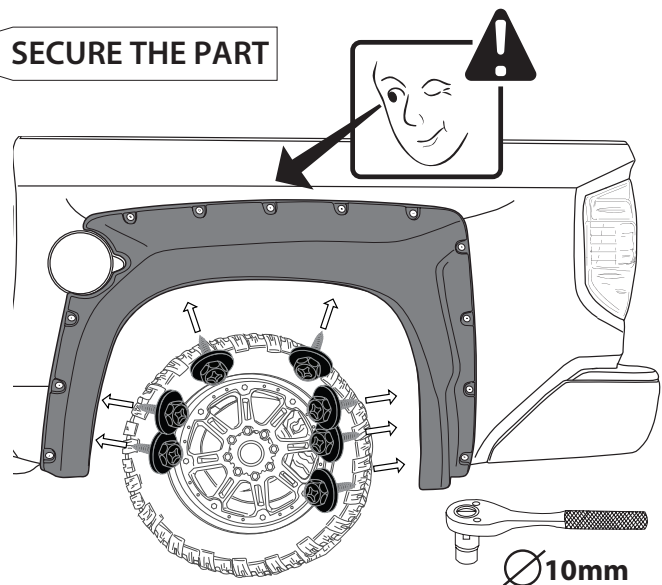

ATTENTION
19 APPLY LOCTITE THREADLOCKER TO SUPER-BOLTS THREAD

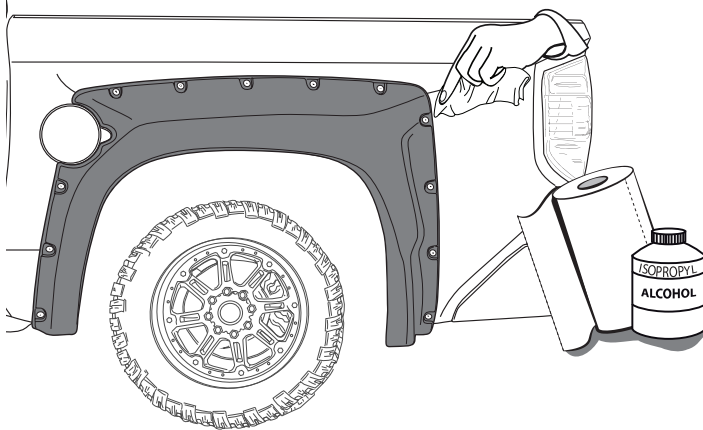
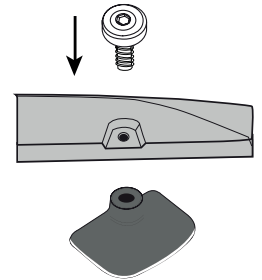
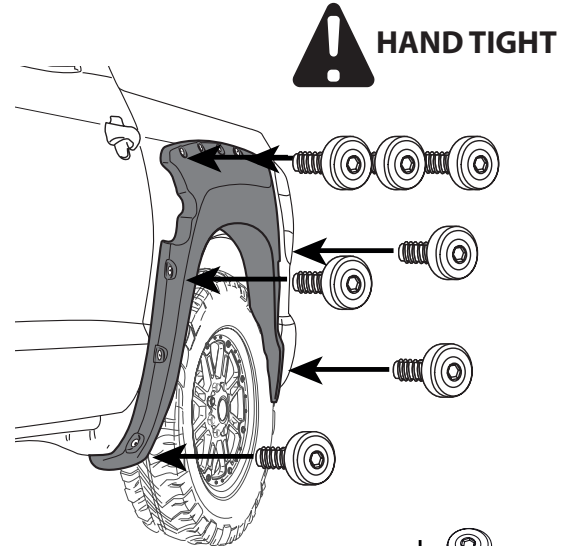
21 CLEAN THE GREASE PENCIL MARK

20 PLACE SUPER-BOLTS

INSTALLED PARTS
